

Sustainable Fisheries Guide

A resource describing sustainable
fishing methods and effects



June 10, 2005

Introduction

Sustainable fisheries are very focused fisheries, catching the target species and little else. Waste and by-catch are minimal. They are generally passive fisheries, not active. The catch is usually fresh. Sustainable fisheries are such because fish are removed at an age and volume that does not affect the stocks' ability to reproduce at a productive rate.

Fishing technique and area of capture are two of the most important factors to be considered when judging the sustainability of a fishery. Different fishing methods are more acceptable at different times and in different areas for each species. An indiscriminate longline fishery during the 1970's was responsible for the crash of Atlantic Swordfish populations, while today, halibut longlining in Alaska is a well-managed, sustainable fishery which successfully addresses all management issues. Sustainable fishery methods may include encircling seine nets, long lines, hook and lines, jigging, weirs, traps, harpooning, gillnetting, diving, and trolling.

Broad based consumer boycotts which advocate the boycott of an entire species, irrespective of fishing method or area of capture only harm the greatest proponents of conservation, the small-scale sustainable fishermen. Consumer boycotts put the sustainable fisherman, who has an interest in the stewardship of our resources, out of business while failing to prevent industrialized fishing vessels from moving on to other species and waters.

Sustainable fisheries management is complicated; myriad factors are in constant flux. When trying to make responsible decisions we must be well informed to judge each fishery on its own merits, as well as being aware of the effect these decisions have on the lives of the people who are involved in fisheries.

Statement of Purpose

To support and encourage the use
of local sustainable seafoods.



Harvesting Techniques

Longline

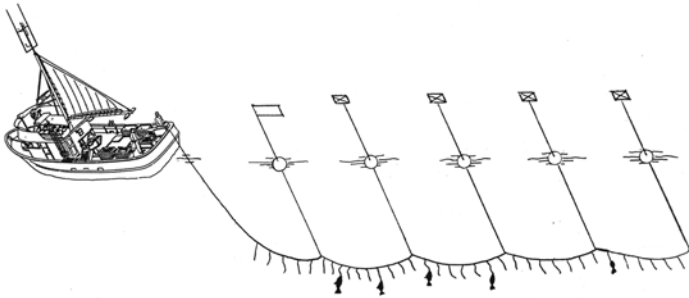

Longlining uses baited hooks on offshoots of a single main line to catch fish at any depth. The line can be anchored at the bottom in areas too rough for trawling, or set adrift, suspended by floats.

Trawling or Dragging

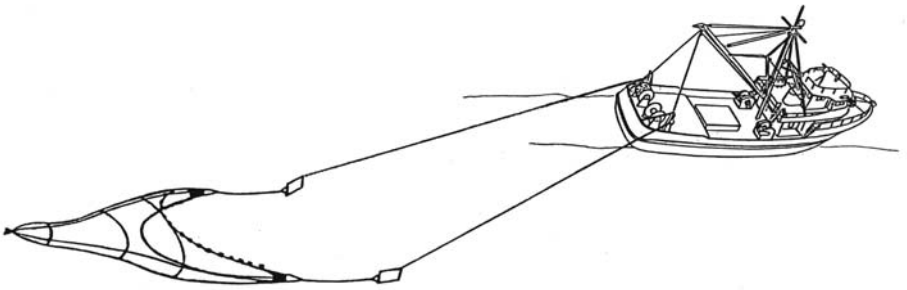

Trawling or Dragging is the method of fishing responsible for the greatest percentage of fishery landings. Trawling is simply described as towing a net through water. A trawl net is funnel-shaped and can harvest bottom-dwelling fish when dragged along the ocean floor. Mid-water trawling targets thick schools of pelagic fish. Mid-water trawlers tow a net through the water column between the surface and the bottom, resulting in less impact on fishery habitat and by-catch.

Purse Seines

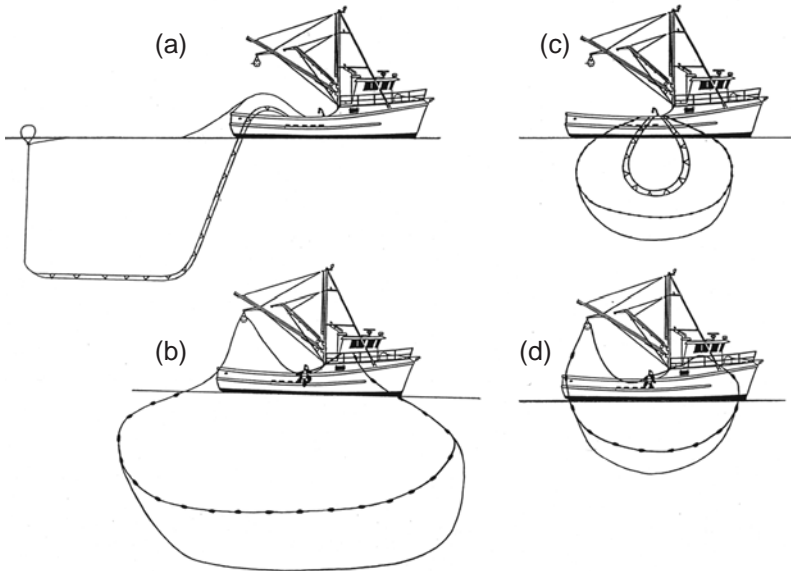

Purse seines are walls of netting used to encircle entire schools of fish at or near the surface. A drawstring cable is threaded through the bottom of the net. When the cable has pulled the netting tight, enclosing the fish in a pouch, the catch is hauled on board with a dip net in a process called brailing.

Gillnetting

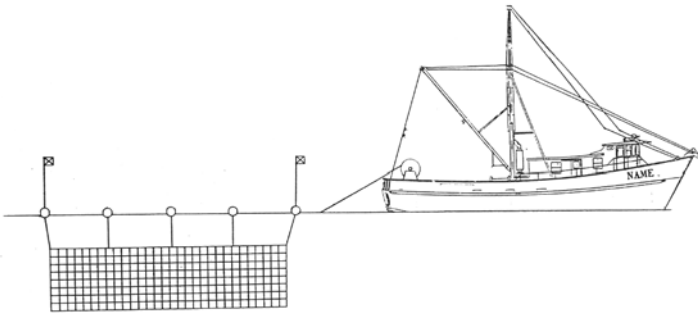

Gillnetting, a passive method, can be used to harvest bottom or pelagic fish. A gillnet is a wall of netting set in a straight line, equipped with weights at the bottom and floats at the top, and is usually anchored at each end. Fish swim through the virtually invisible netting and are entangled when their gills are caught in the webbing, hence the name gillnetting. If allowed to drift freely, the method is referred to as driftnetting.

Trolling

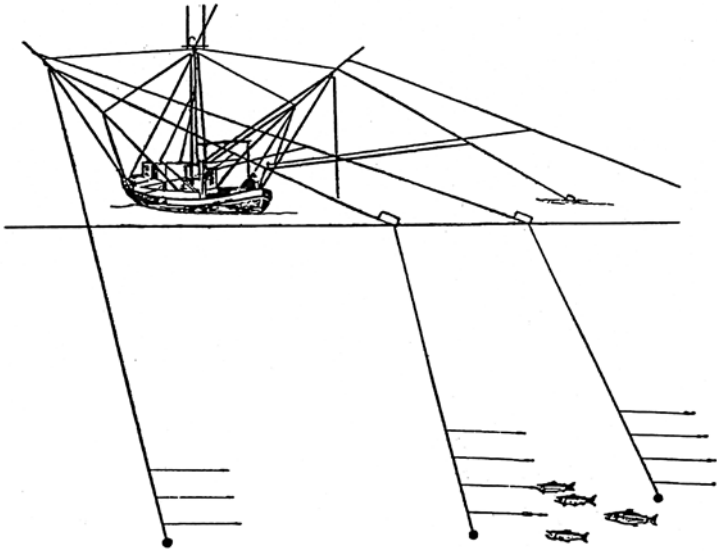

Trolling is simply a moving hook and line towed as single fishing lines behind a moving boat.

Weirs

A weir is a passive fishing method consisting of brush or twine fences permanently attached to the bottom. Two prolonged fences called leaders direct fish to swim voluntarily into successive enclosures known as the heart, pound and pocket.

Fish Traps

Similar to weirs, these traps are instead constructed with netting or wire. They are designed to float where bottom terrain prohibits stakes or pilings. Floating traps are held in place with anchors, the bottom of the trap being covered with netting.

Jigging

Jigging is the setting of a line, with baited hooks or lures, that is continually jerked. The motion, achieved by hand or with a jigging machine, induces fish to take the hook.

Harpooning

Used extensively in the whaling days, harpoons are still used today to catch swordfish, shark and tuna. Thrown by hand or shot by mounted guns, harpoons are each tipped with a barb which is attached to a long line with a buoy at the end. The line is free of the boat and fish are followed with the assistance of the buoy until they tire and can be hauled aboard.

Hook and Line

This method involves a hand line or rod-and-reel, sometimes with more than one hook.

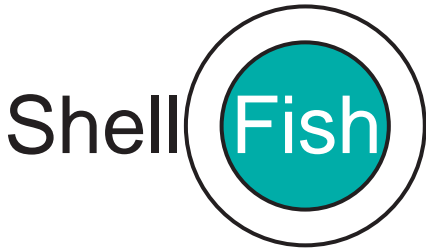

Harvesting Techniques

Dredging

Commonly used for the commercial harvesting of scallops, clams, oysters and mussels, a dredge consists of a metal rectangular frame to which a bag-shaped net of metal rings has been attached. The frame's lower end is called the raking bar and is often equipped with metal teeth used to dig up the bottom. The frame is connected to a towing cable and dragged along the sandy floor, much like a trawl net. Variations include hydraulic or jet dredges, which use pressurized water to stir up deep-burrowing clams, and suction dredges, which use pump-driven suction to suck the shellfish up a pipe to the boat.

Tongs

Various types of rakes are used to harvest clams and oysters. Basket rakes are equipped with wire mesh baskets to hold the catch, and bull rakes have very long handles for operation from a skiff.

Traps or Pots

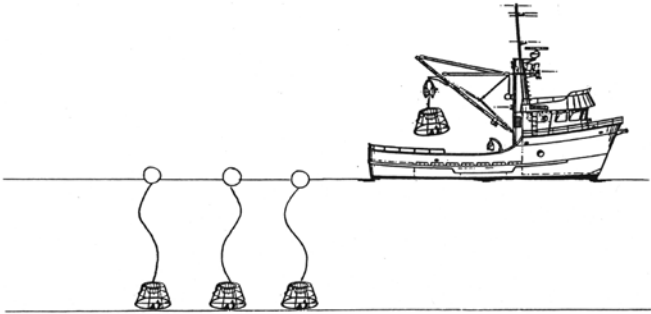

Lobster Pot

Crab Trap

Pots or traps are often designed specifically for one type of fish or shellfish. Generally baited and equipped with one or more funnel openings, they are weighted to rest on the bottom. They have a buoy at the surface to mark the location of the pot or trap.



Fishing Effects

Fishing Technique	Direct by-catch effects
<p>Trawling and Dredging</p> <p>non-selective method</p>	<p>Bottom trawl is responsible for high mortality of many by-catch species. Mid water trawl can be more selective.</p>
<p>Longlining</p> <p>not highly selective; some interaction between other pelagic fisheries</p>	<p>Mortality of by-catch and immature fish. Ancillary factors include when and where set and how often tended. Halibut longlining is okay while swordfish can be questionable.</p>
<p>Seining</p> <p>moderately selective</p>	<p>Some by-catch of other species associated with schooling fish.</p>
<p>Beach seining</p> <p>low selectivity, determined by mesh size</p>	<p>Some by-catch concerns about catch of juveniles of non-target species.</p>
<p>Gillnetting</p> <p>selectivity determined by mesh size and location</p>	<p>Some by-catch. Ancillary factors include when and where set and how often tended. Lost and damaged net can</p>
<p>Trolling, Jigging, Hand-lining and Hook-and-Line</p> <p>moderately selective</p>	<p>Little by-catch if hook size is appropriate to target species.</p>
<p>Trapping and Potting</p> <p>selective</p>	<p>Selective but some by-catch.</p>
<p>Diving</p> <p>highly selective</p>	<p>No by-catch when done properly</p>

Indirect Effects Effects

upon habitats

Discarded trawl trash changes food web, increases populations of scavengers e.g. seabirds, sharks, crabs. Changes to benthic invertebrate communities. Discarded net fragments entangle marine animals and birds.

Reduction of hard substrate, structural damage to reefs and loss of vegetated habitats.

Lost and broken lines can entangle fish, marine mammals, birds and vessels.

Low habitat impact

Low habitat impact

Potential sea-grass destruction

continue to fish and entangle wildlife. Laws require use of cotton ties in corners which ameliorates long term effect.

Low habitat impact

Low habitat impact

Potential habitat damage from trapping in fragile areas

Possible habitat damage from divers and trampling

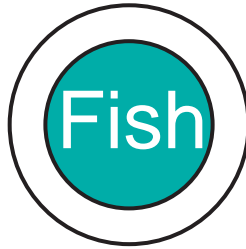

Sustainable Advisory List



This icon indicates that a fishery has some positive aspects such as method and area of capture or a new management plan, yet may have negative factors. These might include a history of over fishing or gear selection that is not ideal, somewhat like the difference between certified organic produce and transitional produce. Make your own decision.

This list is not static. The state of our fisheries may change at any time due to ocean conditions, management plans or a number of other factors. Any corrections, feedback or new information will be duly noted and updates to this list will be posted at www.webseafood.com.

Anchovy *Engraulis mordax*

Huge schools of anchovy are captured in seine nets with very little by-catch. The various anchovy populations in U.S. waters are currently abundant and appear to be healthy.

Black Cod *Anoplopoma fimbria*

Alaskan black cod is caught by longline or pot and like the Alaskan longline halibut fishery, it is a well-managed quota-based fishery. There is a trawl-based fishery in the California, Oregon and Washington waters, but it has a history of poor management. Alaskan black cod is a terrific substitute for Chilean Seabass.

Catfish *Ictalurus punctatus*

Catfish are aquacultured in closed freshwater ponds, having little impact on wild fish or the environment. A catfish like species from Vietnam, also farm-raised, is called Bafa.

Clam-Manila *Tapes japonica*

Commercial supply is 100% maricultured. Small growers such as those in Tomales Bay, use Rack and Bag technique which suspends clams off the bottom, a faultless industry. Larger farms plant clams in gravel beach areas then rake them up when mature, disturbing the inherent structure of the community.

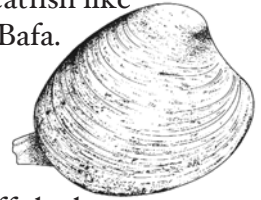

Clam-Littleneck *Protothaca staminea*

Hardshell Eastern Littlenecks are still quite abundant despite many years of intensive harvesting. Good management practices, better enforcement and the increasing importance of aquaculture seem to have ameliorated many of the supply problems experienced during the 1980's. Coastal water quality effected by urban runoff carrying potentially toxic substances seems to be the greatest concern at present. All bottom-maricultured and most wild littlenecks are hand-raked, having little impact on the sandy substrate these clams enjoy. Littlenecks from deep waters are often dredged, which impacts essential fisheries habitat.

Crab-Dungeness *Cancer magister*

The Dungeness crab fishery is a pot fishery with restrictions on size, gender (males only) and season. While considered a well managed fishery, natural fluctuations in stock size do occur. There is little habitat impact and only minor issues of by-catch.

Crab-Softshell, blue *Callinectes sapidus*

In the southeastern United States an industry is fashioned around capturing blue crabs just prior to molting. A practiced eye determines which crabs are ready. These crabs are held in live tanks until they shed their shells and become the delicacy we know as the soft shell crab. The labor and expertise this operation requires adds great value to each crab. To add value to raw product is the ideal formula for preserving a limited resource while maintaining revenue and jobs. Although southeast Atlantic bay and estuary water quality has suffered from excessive farm run-off which impacts crab habitat, progress is being made.

Halibut-Alaska *Hippoglossus stenolepis*

Prior to 1960, the Pacific halibut was fished to the verge of extinction. An intensely regulated program was very successful in rebuilding the halibut fishery back to record levels. The present well managed, long line fishery produces top quality halibut with accountability for by-catch and little habitat interference.

Halibut-California *Paralichthyes californicus*

Although not a true halibut but rather a giant flounder, there is a successful trammel net and hook and line fishery centered in the Bay Area producing top quality fish. The current high yield of large fish seems to indicate good recruitment for upcoming years. Regulations address minimum size and areas. 2001 regulations have phased out gillnetting but a small trawl industry does exist.

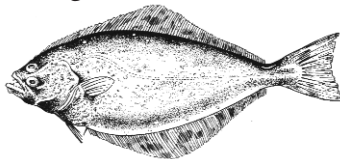

Herring *Clupea harengus pallasii*

Atlantic and Pacific herring are abundant. Very little by-catch is involved in seine herring fisheries. Although human consumption of these fish has very little impact on populations, commercial fishing fleets that “fish down the food chain” targeting small, pelagic fish for fertilizer, fish oil and animal feed are a threat to this critical part of the marine food web.

Lobster *Homarus americanus*

The lobster is perhaps one of the only species that’s been intensively fished for 150 years and is doing better today than ever. The habitat-friendly use of lobster pots, size restriction and regulations against possessing breeding females add up to a well-managed fishery. The preponderance of small sized lobsters make some scientists skeptical about the viability of lobster stocks.

Mackerel *Scomber japonicus*

Dense schools of these small pelagic fish allow for specific targeting with seine nets. Very little by-catch, no habitat impact. Same concern as herring “fishing down the food chain.”

Mahi-Mahi *Coryphaena hippurus*

Mahi-mahi, one of the most stunningly beautiful fish in the ocean, inhabits all of the tropical and subtropical seas of the world. The mahi-mahi is a prolific breeder; the female may spawn 3 to 4 times per year, and grows quickly, as its lifespan is a mere 4-5 years. Their rapid growth and short life span allow them to sustain heavy catch efforts without fear of over fishing. Mahi-mahi is commercially harvested by hook-and-line. Stock assessment is non-existent and unregulated.

Mussel *Mytilus edulis*

Probably 100% of the mussels sold on the West Coast are the superior quality maricultured mussel. While maricultured fish are detrimental to the environment and wild stocks, maricultured shellfish have little impact on habitat, or by-catch. Shellfish farmed via off-bottom methods, such as rack and bag or on lines, have the least impact on seafloor habitat. Some wild East Coast mussels may be dredged and sold locally.

Sustainability in Practice

California's Herring Roe Fishery

The fishery for Pacific herring in California has been through three different phases. The first, taking place in the early 1900's was for fishmeal. The second, which occurred in the mid-1950's, was for canning - as a replacement for declining sardine stocks. The third and current phase began in 1970-71 and is for roe - principally for export to Japan where the egg skeins are called kozonoko. The fishery takes place as the fish come in from the ocean to estuaries, beginning in November of each year. Ninety percent of California's fishery takes place in San Francisco Bay from December to early March, with small fisheries also occurring in Tomales Bay, Humboldt Bay and Crescent City. The San Francisco Bay fishery is the largest for herring south of British Columbia and is presently the United States' only "urban commercial fishery." The fishing can be observed first hand from high-rise office buildings in San Francisco and Oakland as well as along the shorelines from Sausalito to the South Bay.

The herring are caught with gillnets that select for larger adult fish, avoiding the younger year classes. As a result of legislation by the late State Senator Peter Behr, the amount of herring available for harvest is determined by an annual quota based on estimates of the population's spawning biomass. Quotas are set at between 10 and 15 percent of that spawning biomass. Only a few hundred permits exist for the fishery and fishermen holding those permits have generally supported the conservative management.

To support the management of the fishery, the fishermen holding the permits pay a landing tax and buy a herring stamp that supports the research necessary to make accurate spawning biomass estimates and pay the enforcement costs. A herring advisory committee made up of permit holders meets with Department of Fish & Game scientists, managers and wardens to advise on the setting of the annual regulations and promptly address problems that arise in the fishery. For more information, go to: <http://www.nap.edu>.

Oyster *Crassostrea gigas, Ostrea edulis, Crassostrea virginica*

All of the oysters that are grown and sold on the West Coast are maricultured. While maricultured fish are detrimental to the environment and wild stocks, maricultured shellfish have little impact on habitat or by-catch. They may even improve water quality where grown. Shellfish farmed via off-bottom techniques, such as rack-and-bag or lines, have the least impact on seafloor habitat. Gulf and Atlantic seaboard oysters may be dredged, which adversely effects fishery habitat.

Prawn-Spot *Pandalus platyceros*

Spot prawns from well-managed pot fisheries in Alaska are heavily regulated, less so in California. Trawl fishery, with the problems of by-catch and habitat destruction, is the major fishery in California.

Rockfish *Sebastes spp.*

Of the 52 species of rockfish found off the coast of California, some are threatened such as the bocaccio and canary rockfish. Some, like the chilipepper, are in good shape. Hook and line fishermen target a particular species, have little impact on essential fisheries' habitat, are responsible for very little by-catch, and are able to avoid juvenile fish through hook size. Family subsistence

Salmon-Alaska *Oncorhynchus tshawytscha* (Chinook), *O. kisutch* (Coho), *O. nerka* (Sockeye), *O. gorbuscha* (Pink), and *O. keta* (Chum).

The Alaskan fishery consists of all five species of Pacific salmon that are caught by troll, gillnet or purse seine gear. The Alaskan fishery is regarded as well managed and its fish are abundant due to their protected habitats. Alaskan salmon was the first fishery to be certified with an “eco-label” as sustainable by the Marine Stewardship Council.

Marine Stewardship Council

Certifying Sustainably-Harvested Fish

The Marine Stewardship Council (MSC) is an independent non-profit, non-governmental, international certification organization based in London. Established in 1998 by the World Wildlife Fund (WWF) and Unilever, one of Europe’s leading seafood suppliers, its purpose is to investigate and certify fisheries as sustainable. To date, it has certified a handful of fisheries around the world, including Australian rock lobster and Alaska salmon. In the next decade it is expected that many of the fisheries sustainably harvested or farmed around the world will seek to be certified to give them better access to markets of discriminating buyers. For more information, go to: www.msc.org.

Salmon-California *Oncorhynchus tshawytscha*

Although California has four different runs of Chinook (king) salmon, as well as coho (silver), it is the abundant fall-run Sacramento River kings, taken in the ocean troll fishery with barbless hooks, that are targeted and brought to market.

Sand Dab *Citharichthys sordidus*

The Pacific sand dab is a wonderful little fish found in great abundance off our California coast. One of the most numerous fish along the West Coast, the sand dab, in chameleon-like fashion, is able to change color and pattern to match sand, gravel or shell rubble, and goes unnoticed by prey. Danish seines account for many sand dabs with very little by-catch and minimal habitat impact. Dense schools of sand dabs are easily targeted by the trawl fishery, reducing by-catch but having some impact on habitat.

Sardine *Sardinops sagax*

During the 1930's and '40's the Pacific sardine accounted for one-fourth of all the fish landed in the United States. Due to poor fishery management and global weather conditions the sardine industry totally collapsed in the early 1950's. Thanks to favorable ocean conditions and strict management, the sardine is in the midst of an explosive recovery. Highly targeted seine netting accounts for very little by-catch or habitat impact.

Scallop *Placopecten magellanicus*

The Sustainable Fisheries Act of 1996 mandate to improve regulation of scallop stocks, along with some gear improvement, has led to an extraordinary rebound in scallop populations. Higher catch results than have been seen in 40 years have been reported. Although scallop trawl gear has recently been improved, it is still the weak link in this fishery from an environmental point of view.

Shrimp-Turtle Free *Penaeus chinensis*

Shrimpers along the North Carolina and Georgia coasts have long been in the forefront of responsible fisheries management. In the deep water off the Southeast Atlantic coast there is little turtle grass to attract juvenile fish, just hard bottom; therefore, there is much less by-catch and fisheries habitat impact than in the Gulf of Mexico. Shrimp stocks in this area are closely monitored by state and federal authorities to insure a healthy fishery. Decisions on when and where to shrimp are made on a seasonal basis.

Skate *Raja erinacea*

Over-fishing of the gadoids (cod, pollock, haddock and hake) and flatfish has led to a shift in the makeup of the biomass on Georges Banks. Valuable ground-fish populations have declined, while lower-value small elasmobranchs (skates and dogfish) have increased substantially, relative to the total biomass. Because skates are part of the New England ground-fish management plan, they are tallied into catch figures, thus impacting catch regulations. For this reason, fishermen will at times avoid catching skate so as not to impact allowable catch of higher valued ground-fish. This creates artificial shortages. Skates seem to be abundant, but the usual problems of habitat destruction and by-catch associated with a trawl-based fishery must be taken into account.

Think Globally, Act Locally

Getting Involved With Your National Marine Sanctuary

National Marine Sanctuaries, in addition to providing a bounty of fish by protecting some of the best fishing grounds, offer great programs to learn more about the marine environment and opportunities to get involved in marine conservation. The Gulf of the Farallones National Marine Sanctuary and its non-profit support organization, the Farallones Marine Sanctuary Association, have a number of such programs including its award-winning Beach Watch and SEALS programs. It is also developing a Sea Watch program to involve fishermen and other mariners in the care and conservation of sanctuary waters. For more information, contact the Gulf of the Farallones National Marine Sanctuary at: <http://farallones.nos.noaa.gov> and the Farallones Marine Sanctuary Association at: <http://farallones.org>.

Sole- Petrale, English



Eopsetta jordani, Pleuronectes vetulus

Pacific Coast Petrale and English sole stocks are healthy. All environmental groups classify West Coast flatfish as a “green selection”. The commercial fishery is almost exclusively by trawl without the problems of by-catch and habitat destruction.



Squid *Loligo opalescens*

Over the past five years squid has soared past salmon, swordfish and tuna to become the top seafood species in California by volume and dollar value. New rules are a rare example of government stepping in to regulate a fishery before it has crashed. The good news for many in the fishing community is that after several years of scientific study, the Department of Fish and Game reports that squid populations are healthy, despite heavy fishing. Highly targeted lampara seines account for little by-catch and minimal habitat impact.

Striped Bass *Morone saxatilis*

Years of controversial restrictions on striped bass along the Atlantic Seaboard have paid off. Fisheries officials have declared that striped bass stocks are fully recovered from their depleted levels of the late 1970's and early '80's. Quality striped bass are caught by rod & reel or in weirs (traps), a traditional Native American method of fishing whereby fish are entrapped in a net or stake corral then harvested by hand-brailing with scoop nets.

Swordfish



Xiphias gladius

The status of swordfish and other billfish is not completely understood in the Pacific, but populations are believed to be fished to full capacity. An average sized Pacific swordfish is over 200 lbs., while the average sized Atlantic swordfish is 90 lbs. This is a good indication of the relative health of the respective stocks. The Pacific Fisheries Management Council is currently developing a management plan to ensure sustainability. California regulations allow only harpoon and gill net fisheries which have very little impact on juveniles and by-catch, particularly when compared to Pacific longliners.

Tai Snapper *Chrysophrys auratus*

Tai Snapper of the family Sparidae, or sea breams, are the most important part of the New Zealand inshore fishery. They are caught commercially on longlines, killed immediately, then cooled quickly in brine. Over 30,000 tons of snapper are landed annually in New Zealand and this is the most popular eating fish, both for local consumption and for export. For a description of management, see New Zealand fisheries management below.

Trout *Oncorhynchus mykiss*

Trout are aquacultured in closed freshwater systems, having no impact on wild fish or the environment.

Tuna - Albacore *Thunnus alalunga (Tombo)*

The “white meat” tuna, albacore are taken principally in a troll fishery that occurs off the U.S. west coast during the summer and fall months. The fish are also caught in the Western Pacific and in the Atlantic. Pacific stocks are generally regarded as healthy.

Tuna - Yellowfin *Thunnus albacares* (Ahi)

Yellowfin tunas, both Pacific and Atlantic, are not considered to be overfished, but rather fished to maximum sustainable yield. Fresh yellowfin tuna are most often fished by rod and reel or longline. Pacific bluefin are in much better shape than their Atlantic cousins. The longline fishery does have all of the by-catch issues.

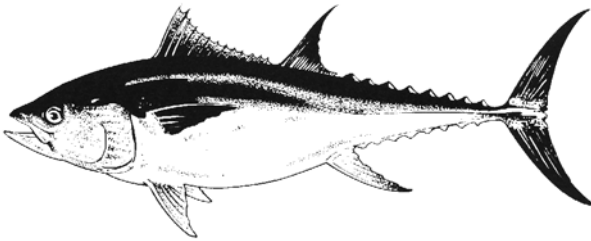

Learning More About Fish

Exploring the West's Great Aquariums

Residents and visitors to the Pacific Coast are fortunate to have some of the world's finest aquariums in their midst, from Aquarium of the Pacific in Southern California to the Northwest's Seattle Aquarium and BC's Vancouver Aquarium. Three of the top aquariums are in Central and Northern California from Monterey Bay Aquarium at Pacific Grove, to the California Academy of Science's Steinhart Aquarium in San Francisco's Golden Gate Park, to the Aquarium of the Bay, located between Piers 39 and 33 on San Francisco Bay. They are each different, and each definitely worth a visit (and probably many more) for those wanting to learn more about marine life and our marine environment. For more information on these three great aquariums, go to:
Monterey Bay Aquarium: www.montereybayaquarium.org
Steinhart Aquarium: www.calacademy.org
Aquarium of the Bay: www.aquariumofthebay.com

White Sea Bass *Cynoscion nobilis*

Perhaps the best news coming out of this fishery is that the populations, at least off California, are believed to be on the upswing. “They’re definitely coming back,” says State Fish and Game biologist Steve Crooks, based in Long Beach. “We suspect a tremendous natural recovery in the stocks.” 2001 regulations have virtually ended all gillnet fishing for white seabass in California. The current rod and reel fishery should help the continuing recovery of stocks while providing top quality fish.

What Others Have to Say

Additional Information Sources About Sustainable Seafood

A number of organizations have put together information and recommendations for sustainable seafood. Two handy wallet size cards have been produced by the Monterey Bay Aquarium and the California Academy of Sciences (Steinhart Aquarium).

For information about the Monterey Bay Aquarium’s “SEAFOOD WATCH - Choices for Healthy Oceans” visit: www.montereybayaquarium.org. For information about the California Academy of Sciences’ “Guilt-Free Guide for the CATCH OF THE DAY” visit www.calacademy.org/calwild.

Another good source of information is the Seafood Choices Alliance, “bringing ocean conservation to the table,” a consortium of chefs, restaurants, seafood suppliers, fishermen and marine conservation organizations. To find out more, visit: www.seafoodchoices.com.

A Conservation Opportunity

Saving the West's Most Important Estuary, Its Fish and Wildlife

Estuaries are critical to the life stages of most of our marine life. This is the area where fresh water from rivers and streams mixes with the salt water of the ocean creating the rich brackish habitats that so many fish and shellfish species thrive in. Of all the estuaries on the Pacific Coast - of North and South America - none is as important biologically as San Francisco Bay. It is the gateway between the Sierras and the largest nursery area for Dungeness crab and provides spawning habitat for Pacific herring. Jack London wrote of its oyster and shrimp fisheries that thrived until World War II. Many leopard sharks, California halibut, starry flounder, English sole and skates are found here.

The great estuary has been filled, dredged, diked, polluted and, in many years, as much as half of its freshwater inflow - the lifeblood of an estuary - is diverted. In the 1960's Save San Francisco Bay Association and others stopped the filling of the Bay. This effort culminated in the passage of the Petris McAteer Act, creating the Bay Conservation & Development Commission. In the 1980's, The Bay Institute of San Francisco focused agency and public attention on the Bay's freshwater needs. And at the beginning of the 21st century, the Institute for Fisheries Resources (IFR), in partnership

with the National Oceanic & Atmospheric Administration's (NOAA) Restoration Center, will initiate a three-year program (January 2003) aimed at assisting citizen and community restoration efforts for San Francisco Bay - its ecosystem, wildlife and fish. For more information, go to:

www.ifrfish.org, and also

<http://www.nmfs.noaa.gov/habitat/restoration/>.

For information on other conservation efforts for San Francisco Bay and its adjoining Sacramento - San Joaquin Delta and tributaries, contact the following organizations:

Save San Francisco Bay Association at: www.savesfbay.org

The Bay Institute at: www.bay.org

You can also contact the Environmental Water Caucus (EWC), a coalition made up of national (Sierra Club, Natural Resources Defense Council, Audubon Society, Environmental Defense, etc.) and regional conservation groups and sport and commercial fishing organizations, working on state and federal policy to better protect the Bay and Delta. The EWC e-mail is: c@dauidnesmith.com.

Finally, for those interested in Bay conservation education, contact the Aquarium of the Bay at:

www.aquariumofthebay.com



Monterey Fish Market, Inc.
Wholesale
Pier 33, San Francisco, CA 94111
(415) 956-1985



Farallones Marine Sanctuary Association
P.O. Box 29386, San Francisco CA 94129
(415) 561-6625



Gulf of the Farallones National Marine Sanctuary
Fort Mason, Building 201, San Francisco, CA 94123
(415) 561-6622



Pacific Coast Federation of Fishermen's Association
P.O. Box 29370, San Francisco CA 94129
(415) 561-5080



Institute for Fisheries Resources
P.O. Box 29196, San Francisco CA 94129
(415) 561-3474

For more information on the
Sustainable Seafood Coalition, call the
Farallones Marine Sanctuary Association
at 415/ 561-6622.